

TRI-GARD 555LS/557LS Signature Series™

Audio Glassbreak Detectors



555LS



557LS

TRI-GARD 555LS/557LS SIGNATURE SERIES™

audio glassbreak detectors employ state-of-the-art Advanced Signature Analysis™ algorithms to sample four bands of audio instead of one or two like most other detectors. Digital Signal Processing (DSP) is used to continuously sample and analyze the sound. Within milliseconds after an audio “event” begins, the microprocessor starts crunching data. Approximately 1200 comparisons and decisions are made before an event is rejected or confirmed about 0.3 seconds later. Eight glassbreak signature models and four false alarm models, stored in memory, are referenced during the confirmation process. The result of this high-tech performance is more accurate glassbreak detection and improved false alarm rejection in tough environments.

TRI-GARD 555LS/557LS FEATURES

- Specified for plate, wired, tempered & laminated glass
- Microprocessor-based for better discrimination
- Advanced Signature Analysis™
- Signature Supervision
- Omnidirectional sensitivity
- Automatic sensitivity adjustments

TRI-GARD 555LS/557LS APPLICATIONS

- Glassbreak protection in residential, commercial and industrial areas
- Protects plate, wired, tempered & laminated glass
- Omni direction detection to protect multiple windows
- Areas with closed drapes or blinds will reduce range.
Test with 517 tester for specific range
- Wall or ceiling mount installations

SPECIFICATIONS

SENSING: Audio/air, open space (enclosed area)

RANGE: 25' for plate, wired, tempered & 20' for laminated glass. These ranges are for 1' X 1' minimum glass size. For glass size down to 6" X 10" the range would be reduced by 1/2.

GLASS SIZE: Above stated range is for 1' X 1'

THICKNESS: Plate—³¹/₄₃₂" to ¹¹/₄₂"

Tempered—¹/₄₈" to ¹¹/₄₂"

Wired—¹/₄₄" to ¹¹/₄₂"

Laminated—¹/₄₄" to ¹¹/₄₂"

SENSING FIELD: Omni-directional

SENSOR: Electret condenser (F.E.T. pre-amp)

OPERATING VOLTAGE: 10–16 VDC filtered and regulated

POWER CONSUMPTION: 30 ma @ 13.6VDC normal, 40 ma @ 16 VDC.

OPERATING TEMPERATURE: 14° to 120° F (-10° to 49° C)

STORAGE TEMPERATURE: -13° to 185° F (-25° to 85° C)

RELAY ACTIVATION TIME: 3 seconds

ALARM LED: Latch or auto reset

ALARM RELAY: SPDT (Form-C)- contacts .1 Amp @ 30 VAC/24 VDC Relay is energized upon power up (C & NC are closed)

TAMPER CIRCUIT: Normally closed switch-contacts 50 milliamps @ 30 VAC/24 VDC.

VOLTAGE MONITOR: Low or no voltage causes alarm relay to open. Low voltage <10 VDC causes red LED to flash slowly

INSTALLATION: Hardwire 6 wires including 2 for tamper

Testing: Follow instructions & test once a year

MOUNTING: Surface—screw and anchors included

COLOR: White or Cabin Brown

SIZE: 3" x 3" x ³/₄₄"

NOTE 1: The use of mini-blinds, shades, drapes* and sun film* can reduce the range of the detector by 50%. Since room acoustics and window coverings can vary considerably, all detector installations should be checked with the 517 tester.

* Not for sound deadening drapes

* Tested w/ 3M sun film #SH2CLAR (3M is a trademark of 3M Company)

MOUNTING LOCATIONS

The Tri-Gard can be mounted on any type of ceiling or wall.

The detector should be no closer than 4 feet from the glass to be protected. Since the sound waves of breaking glass travel directionally out at a 90° degree angle from the broken window, the best mounting location is on the opposite wall, assuming the wall is within detection range.

For maximum performance install the detector in direct line of sight to all glass that you are protecting and locate the detector at least 1 foot from any corner or ceiling.

For best false alarm immunity the detector should be mounted at least 4' from the glass to be protected and from noise sources such as kitchen sinks, stereos, televisions, etc.

WALL MOUNTING

Mount the detector on an opposite or adjacent wall from the glass to be protected.

The unit should be mounted at least 6 feet from the floor. This will ensure that no furniture or other objects will block the direct line of sight, thereby providing maximum glassbreak protection.

NOTE: The unit should not be mounted on the same wall as the glass to be protected.

CEILING MOUNTING

Mount the 555LS/557LS in any location on the ceiling which is in direct line of sight of the glass to be protected.

To ensure maximum glassbreak detection do not mount the detector within 1 foot of any side wall.

Mount the 555LS/557LS on any solid material.

555LS/557LS OPERATIONS AND WIRING

On power-up the microprocessor will momentarily turn on each LED.

LEDs Operation:

- Green LED ON—solid indicates unit is properly powered.
- Green LED OFF—indicates that the relay has dropped out, due to the detector being tripped or no/low power (<10 VDC).
- Green LED BLINKS—slowly to indicate that the unit is in test mode (see test mode).
- Green LED FLASHES—when there are background noises present within the detection range.
- Amber LED ON— solid indicates that the “Signature Supervision” has not been able to test all circuits within the last 120 hours.
- Red LED ON—solid indicates that the detector has been tripped and is in a latched alarm memory condition.
- Red LED FLASHES—to indicate that there is an alarm for low power condition, input voltage is (<10 VDC).

555LS CIRCUIT BOARD

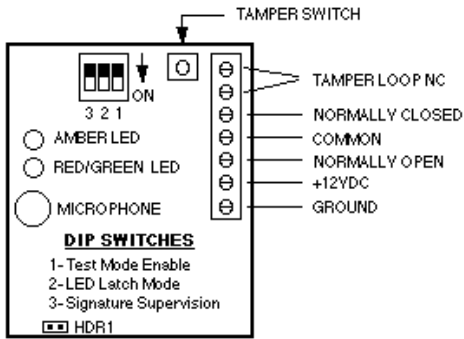

NOTE: Tamper spring is in hardware package with screws

557LS CIRCUIT BOARD

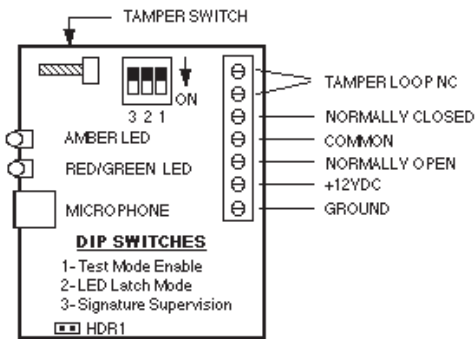

TESTING THE 555LS/557LS

DIP SWITCH 1- (Test Mode Enable)

Test mode allows the installer to properly test the 555LS/557LS with the IEI 515 OR 517 GLASS BREAK SIMULATOR.

NOTE: The 515 tester will test for basic operation of detector, such as microphone response and proper alarm relay operation, but it will not test for proper range. The 517 tester is required for proper range verification.

Manual Test Mode with 515 or 517 Tester:

To enable test mode momentarily move DIP switch 1 from the off position to the on position and then return it back to the off position. The green LED will blink slowly. You have two minutes to test the detector. Each time you trip the detector, indicated by the green LED turning off and the red LED turning on for three seconds, you will re-start the two minute test time (NOTE: the red LED will not latch during test mode even if you have DIP switch 2: alarm memory on). If you do not trip the detector within the two minute test period, the detector will return to normal glass break mode, indicated by the solid green LED. To immediately return to normal glass break mode after the detector is tested correctly, simply interrupt power for one second.

Remote Test Mode with 517 Tester:

To test remotely with 517 tester move DIP switch 1 to the on position. Step back about 10 feet from the detector and press the tester "To Test" button. The detector should now enter test mode indicated by the slowly blinking green LED. Position the 517 near the farthest point of the protected glass and point the tester directly toward the detector. Close any curtains, drapes or blinds and hold tester behind window covering to ensure proper location of detector. Select the specific glass type and size and push the appropriate key on the tester. Observe that the unit trips consistently. When finished you can exit test mode by pressing the tester "Test Off" button, interrupt power momentarily or simply let the 2 minute test window expire.

NOTE: With DIP switch 1 in the on position, test mode can be entered remotely at any time with the 517 tester

NOTE: Test mode does not prevent the 555LS/557LS from detecting breaking glass.

INSTALLATION OPTIONS

DIP SWITCH 2- (Alarm LED Latch Mode)

- OFF-Red LED lights for 3 seconds on alarm and then turns off.
- ON- Red LED will latch in memory upon an alarm. Interrupt power or turn dip switch 2 off & on to reset.

DIP SWITCH 3- (Signature Supervision)

- OFF- Normal operation- without "Signature Supervision".
- ON- Enables "Signature Supervision" processing.

SIGNATURE SUPERVISION™

Using a microprocessor enables the detector to process more data to make better decisions in determining a glass break event and also provide more information back to the user regarding the operating status of the device. A glass break event occurs over a broad frequency range. There are frequencies present from 10 to 40,000 cycles during a glass break event. Signature Supervision monitors the input from the microphone and the associated circuitry to insure that the unit continues to "hear" across the frequency spectrum. If, after 120 hours (5 days), the sensor has not heard the individual frequency elements associated with the signature frequencies within glass break the amber LED will come on and stay latched to indicate a potential trouble situation (NOTE: this does not trip the alarm relay). When the detector has heard those particular frequencies associated with glass break, the amber LED will reset. Clapping, for example, will often produce the range of frequen-

cies that are present in glass break and can be used to reset the unit. Notice that while clapping will reset the Signature Supervision, it will not cause an alarm because it does not meet other criteria that the microprocessor is using to determine a true glass break event. This feature is dip switch selectable.

NOTE: If the amber LED is lit and is unable to be reset by clapping, the customer should contact the installing dealer.

PRE-TESTING THE TRI-GARD 555LS/557LS FOR DESIRED LOCATION

Pre-testing of the detector prior to final installation can be performed to ensure that the detector is installed in the proper location with respect to all glass being protected. The IEI 517 Glass Break Simulator is required to perform this test.

WARNING:

The 555LS/557LS detector has been designed to detect glass break within a specified range from the glass—(25' for plate, tempered, and wired glass and 20' for laminated glass). You should not extend past these rated ranges for any reason. Acoustics of different areas can artificially extend the range of the tester.

1) Connect a 9 Volt DC alkaline battery or 12 VDC power source.

2) Proceed to section: Testing the 555LS/557LS

NOTE: the red LED will flash slowly indicating low voltage (input voltage <10 VDC) and also the relay will not be ener-

THIS DEVICE COMPLIES WITH PART 15 OF THE FCC RULES. OPERATION IS SUBJECT TO THE FOLLOWING TWO CONDITIONS: (1) THIS DEVICE MAY NOT CAUSE HARMFUL INTERFERENCE, AND (2) THIS DEVICE MUST ACCEPT ANY INTERFERENCE RECEIVED, INCLUDING INTERFERENCE THAT MAY CAUSE UNDESIRE OPERATION.

WARNING: Changes or modifications to this unit not expressly approved by the party responsible for compliance could void the user's authority to operate the equipment.

NOTE: This equipment has been tested and found to comply with the limits for a Class B digital device, pursuant to Part 15 of the FCC Rules. These limits are designed to provide reasonable protection against harmful interference in a residential installation. This equipment generates, uses and can radiate radio frequency energy and, if not installed and used in accordance with the instructions, may cause harmful interference to radio communications. However, there is no guarantee that interference will not occur in a particular installation.

If this equipment does cause harmful interference to radio or television reception, which can be determined by turning the equipment off and on, the user is encouraged to try to correct the interference by one or more of the following measures:

- Re-orient or relocate the receiving antenna
- Increase the separation between the equipment and the receiver
- Connect the equipment into an outlet on a circuit different from that to which the receiver is connected
- Consult the dealer or an experienced radio/TV technician for help

gized (common and normally closed will be open).

CAUTIONS

- To improve false alarm rejection do not use for 24 hour applications in occupied areas, areas where white noise, such as air compressors or machinery may be present or within 4 feet of the glass being protected.
- Performance of any audio detection device depends upon an audible signal and may be compromised when detecting glassbreak if little or no sound is generated. For example, avoid installations with sound insulating window coverings.

IEI Limited Warranty:

Because the manufacturer does not install or connect this security device the manufacturer cannot guarantee its performance. Therefore, there are no warranties, expressed or implied (except as stated below), attached to the sale or use of this product.

The manufacturer warrants against defects in material and workmanship in this device for 3 years from the date of manufacture. During the warranty period the manufacturer, at its sole option, will repair or replace free of charge any defective unit returned freight prepaid. This warranty shall remain in force and effect for 3 years provided the unit was properly installed and operated, has not been subject to misuse and has not been repaired or altered other than by the original manufacturer.

The foregoing states the buyer's sole and exclusive remedy for any breach of warranty or for any claim, whether sounding in contract, tort, strict liability, or negligence, based upon any defect in this security device.

The manufacturer shall in no event be responsible for any incidental or consequential damages incurred by the buyer.

This warranty supercedes all previous warranties.



427 TURNPIKE STREET, CANTON, MA 02021 U.S.A.
800-343-9502 OR IN MA 800-733-9502

555/557 REV. 1.01 617-5550 MADE IN U.S.A.